

LED Driver Constant Voltage 48V Surface (For Suspended Mounting) 100W (Incl. Black Power Feed Cable 2000)
Black Structure

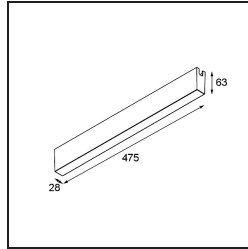
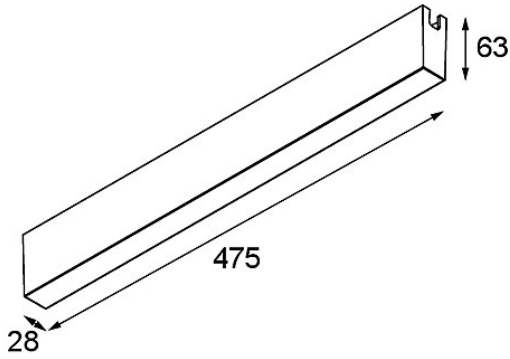

Spezifikationen

Material	13453432
Leuchtmittel enthalten	Nein
Anzahl Lichtquellen	0
Eingangsspannung	230 V
Schutzklasse	I
Schutzart	20
Glühdrahtprüfung (°C)	960
Innen/Außen	Innen
Montage	Aufbau
Verstellbarkeit	Not Applicable
Primärfarbe & Primäres Finish	Schwarz, Strukturiert
Bruttogewicht (g)	1332,0