

Datum

Klant

Project

Soort

LED Driver Constant Voltage 48V Surface (For Surface Mounting) 100W White Structure

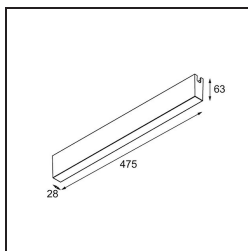
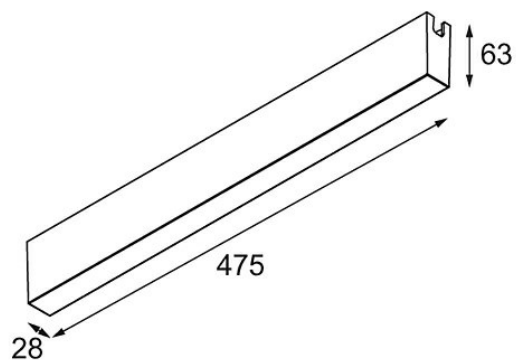

Specificaties

Materiaal	13453309
Lamp inbegrepen	Neen
Aantal Lichtbronnen	0
Ingangsspanning	230 V
Elektriciteitsklasse	I
IP-klasse	20
Gloeidraadtest (°C)	960
Binnen/Buiten	Binnen
Montage	Opbouw
Verstelbaarheid	Not Applicable
Primaire Kleur & Primaire Afwerking	Wit, Structuur
Brutogewicht (g)	1133,0