

Power Feed and Suspension Kit Round 9P Flat Moon (3) Triangle (Incl. Power Feed Cable & Suspension Cable 4000) Black Structure

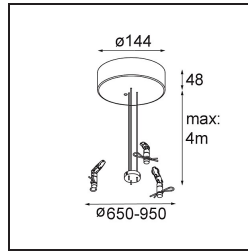
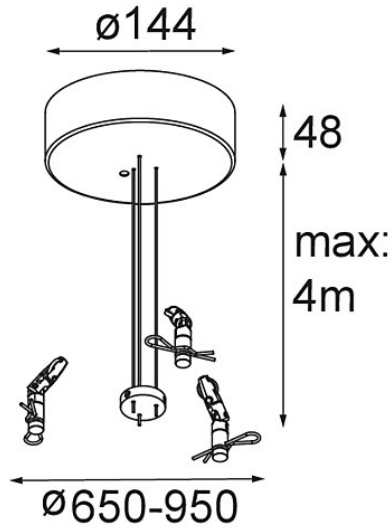

Specifications

Material	11066232
Lamp Included	No
Number of Light Sources	0
Input Voltage	230V
Electrical Class	I
IP Rating	20
Glow wire rating (°C)	960
Indoor/Outdoor	Indoor
Application	Ceiling
Adjustability	Not Applicable
Primary Colour & Primary Finish	Black, Structure
Gross weight (g)	1660.0