

*Power Feed and Suspension Kit Round 9P Flat Moon (3) Triangle (Incl. Power Feed Cable & Suspension Cable  
4000) White Structure*

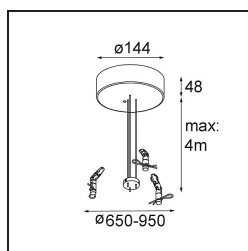
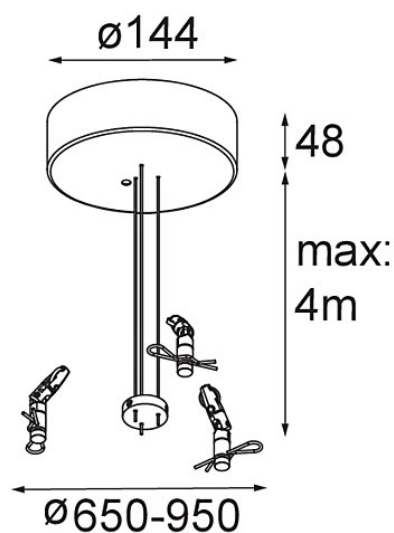

**Caractéristiques**

Matériaux	11066209
Ampoule incluse	Non
Nombre de Sources Lumineuses	0
Tension d'Entrée	230 V
Classe Électrique	I
Indice de protection IP	20
Essai au fil incandescent (°C)	960
Intérieur/extérieur	Intérieur
Application	Plafond
Ajustabilité	Not Applicable
Couleur Principale & Finition Principale	Blanc, Structure
Poids brut (g)	1660,0