

*Power Feed and Suspension Kit Round 5P Flat Moon (3) Triangle (Incl. Power Feed Cable & Suspension Cable
4000) White Structure*

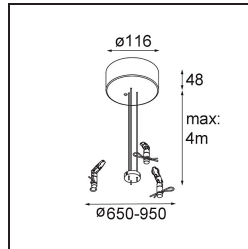
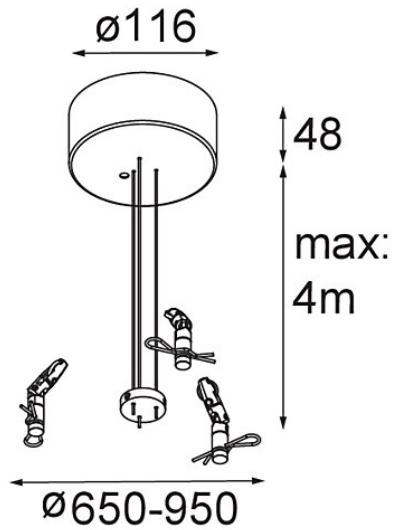

Specificaties

Materiaal	11066109
Lamp inbegrepen	Neen
Aantal Lichtbronnen	0
Ingangsspanning	230 V
Elektriciteitsklasse	I
IP-klasse	20
Gloeidraadtest (°C)	960
Binnen/Buiten	Binnen
Toepassing	Plafond
Verstelbaarheid	Not Applicable
Primaire Kleur & Primaire Afwerking	Wit, Structuur
Brutogewicht (g)	1375,0