

Datum

Kunde

Projekt

Art

*Installation Housing 257x327x147*

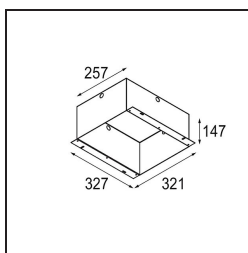
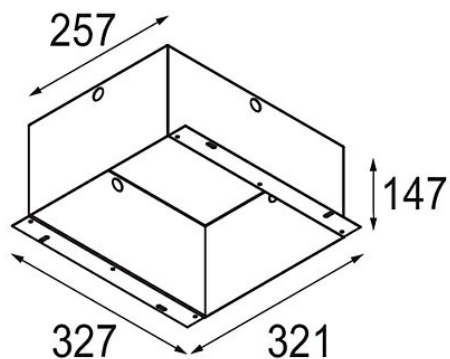

### Spezifikationen

|                        |                |
|------------------------|----------------|
| Material               | 10400330       |
| Leuchtmittel enthalten | Nein           |
| Anzahl Lichtquellen    | 0              |
| Schutzart              | 20             |
| Glühdrahtprüfung (°C)  | 960            |
| Innen/Außen            | Innen          |
| Anwendung              | Decke, Wand    |
| Verstellbarkeit        | Not Applicable |
| Bruttogewicht (g)      | 2100,0         |