

LED Driver Constant Voltage 48V Surface (For Suspended Mounting) 100W White Structure

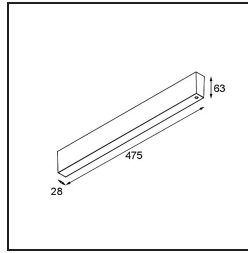
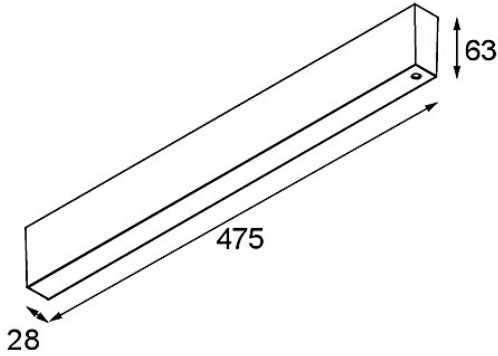

Specifications

Material	13456209
Lámpara Incluida	No
Número de fuentes de luz	0
Voltaje de entrada	230V
Clasificación eléctrica	II
Clasificación del IP	20
Clasificación de hilo incandescente (°C)	960
Interio/Exterior	Interior
Montaje	Superficie
Ajustabilidad	Not Applicable
Color principal & Acabado principal	Blanco, Estructura
Peso bruto (g)	1316,0
Voltaje de entrada	220-240V AC / 50-60Hz
Factor de potencia	0,95
Max. drivers on MCB 16A type B	10