

*LED Driver Constant Voltage 48V Surface (For Suspended Mounting) 150W Black Structure*

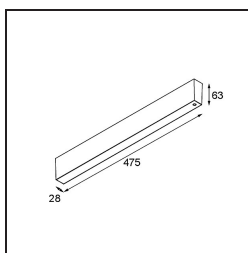
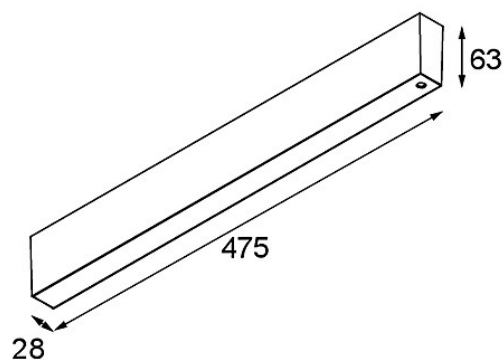

### Specifications

Materiale	13456132
Lampadina inclusa	No
Numero di fonte luminosa	0
Volt in ingresso	230V
Classificazione elettrica	II
Grado IP	20
Test filo a caldo (°C)	960
Interno/Esterno	Interno
Montaggio	Superficie
Orientabilità	Not Applicable
Colore primario & Finitura primaria	Nero, Strutturata
Peso lordo (g)	1341,0
Volt in ingresso	220-240V AC / 50-60Hz
Temperatura ambiente	-25°C to +45°C
Fattore di potenza	0,95
Max. drivers on MCB 16A type B	8