

Date
Customer
Project
Type

LED Driver Constant Voltage 48V Surface (For Suspended Mounting) 150W White Structure

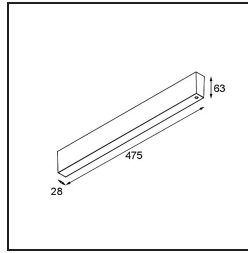
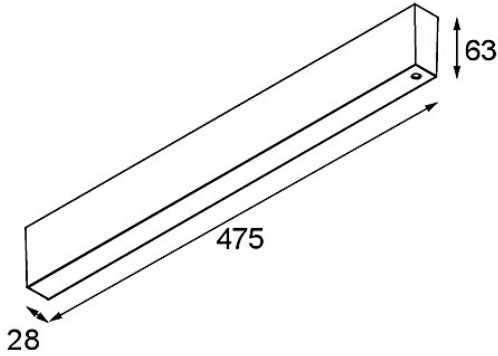

Specifications

Material	13456109
Lamp Included	No
Number of Light Sources	0
Input Voltage	230V
Electrical Class	II
IP Rating	20
Glow wire rating (°C)	960
Indoor/Outdoor	Indoor
Mounting	Surface
Adjustability	Not Applicable
Primary Colour & Primary Finish	White, Structure
Gross weight (g)	1341.0
Input voltage	220-240V AC / 50-60Hz
Ambient temperature	-25°C to +45°C
Power factor	0.95
Max. drivers on MCB 16A type B	8