

LED Driver Constant Voltage 24V Surface (For Suspended Mounting) DALI/Push-Dim 100W (Incl. Power Feed Cable 2000) White Structure

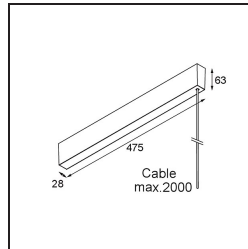
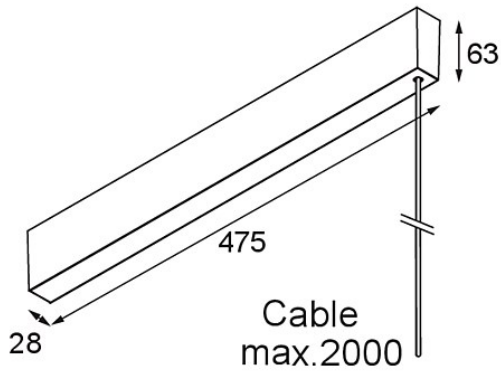

Spezifikationen

Material	13551709
Leuchtmittel enthalten	Nein
Anzahl Lichtquellen	0
Eingangsspannung	230 V
Schutzart	20
Dimmprotokoll	DALI, Push-Dim
Innen/Außen	Innen
Montage	Aufbau
Verstellbarkeit	Not Applicable
Primärfarbe & Primäres Finish	Weiß, Strukturiert
Bruttogewicht (g)	1158,0