

LED Driver Constant Voltage 24V Surface (For Suspended Mounting) Non-Dim 100W (Incl. Power Feed Cable 2000) Black Structure

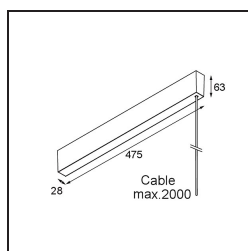
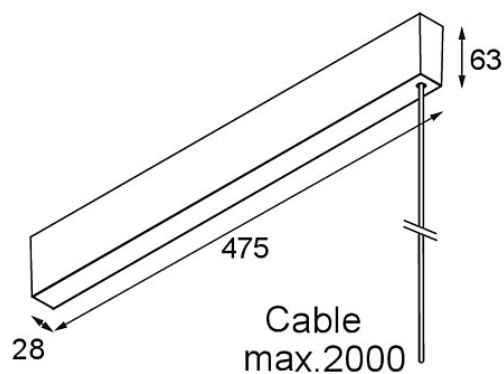

Caractéristiques

Matériaux	13551832
Ampoule incluse	Non
Nombre de Sources Lumineuses	0
Tension d'Entrée	230 V
Indice de protection IP	20
Protocole de Variation	Non Dimmable
Intérieur/extérieur	Intérieur
Montage	En Surface
Ajustabilité	Not Applicable
Couleur Principale & Finition Principale	Noir, Structure
Poids brut (g)	1096,0